



CPL-1288 Specifications

- Expander Threshold** -80 dBu to +10 dBu
- Expander Ratio** 1:1 (off) to 1:4 (gate)
- Expander Attack** -5msec (fixed)
- Expander Release** 200 mSec (fixed)
- Compressor Threshold** -40 dBu to +20 dBu
- Compressor Ratio** 1:1 (off) to infinite:1 (limit)
- Compressor Attack** 0.5 mSec to 100 mSec
- Compressor Release** 0.5 sec to 2 sec
- Limiter Threshold** 0 dBu to +20 dBu (off)
- Limiter Release** 50 mSec (fixed)
- Gain Recovery** 0 dB to +20 dB
- Input XLR (balanced)** 20 k ohms, Pin 1 =ground, Pin 2 =positive phase, Pin 3 = negative phase
- Input TRS (balanced)** 20 k ohms, Sleeve = ground, Tip = positive phase, Ring = negative phase
- Input/Output 1/4" (unbalanced)** 10k ohms, Tip = input, Ring = output
- THD** Less than 0.1%, 20 Hz to 20 kHz (10 Hz to 80 kHz BW)
- Signal-to-Noise** 97dB (0 dBu reference level)
- Frequency Response** 20Hz-64 kHz (+0 dB/-1dB)
- Output Impedance** 100 ohms (XLR and 1/4")
- Meters** Two 12-segment LED arrays, two 10-segment LED arrays, two activity LEDs
- Power Requirements** U.S.: 100-120 VAC 50/60Hz (15 watts nominal; Export: 230 VAC 50/60 Hz (15 watts nominal)
- Dimensions** 19" W x 9.25" D x 1.75" H
000 mm W x 000mm D x 000mm H
- Weight** 7.3 lbs / 3.3 kg

What sets this compressor/limiter apart from all the rest? Plenty of carefully-thought-out extra features.

It all starts with a short signal path to reduce coloration and the use of a premium THAT™ chip-set. Simply put, the CPL-1288 sounds good even at relatively extreme settings (thanks to soft-knee topology that provides smooth transition curves) and doesn't add noise to your signal chain.

"See-It-All" metering.

Few if any other compressor/limiters have the CPL-1288's elaborate LED metering system. Instead of a chincey 3-LED display that only works with the compressor, you get visual feedback for all functions, including limiting and expansion. And the level meters can be switched between input and output.

Small details. Big differences.

We added an 18dB per octave 150Hz Low Cut filter to the side chain to discourage compressor pumping from bass frequencies.

In stereo link mode, the Crest CPL-1288 uses true RMS summing to average left and right input material, resulting in a far more accurate stereo image.

CPL™-1288

- Compressor, limiter and expander functions are available simultaneously
- Dual-mono or linked stereo with true RMS summing
- Expander section with threshold and ratio adjustments
- Easy monitoring of processors with 12-LED gain meter and 10-LED input/output level meter
- De-esser and low-cut filters
- Output level control
- Side-chain inserts
- Balanced XLR and balanced/unbalanced 1/4" TRS inputs and outputs, plus...
- One-cable (per channel) operation with mixer inserts

Included is a De-esser tuned to male and female voices in the 7kHz range. Placed *before* the side chain, it cuts sssssibilance.

We even spec-ed a 2-color LED for the bypass so you can tell at a glance whether the CPL-1288 is engaged (green) or defeated (red).

Getting the idea? Crest has put a lot of thought into this processor so you can get a lot out of it — both in live sound and studio applications. ■



Quality dynamics processing for:

- Rock bands
- Churches
- Mobile DJs
- Clubs and restaurants
- Corporate A/V

- School auditoriums
- Hotel ballrooms
- Conference centers
- Rental systems
- Trade shows
- Museums and libraries

DOWNLOADS @ www.crest-performance.com

- This spec sheet [CPL1288Spec.pdf](#)
- CPL-1288 Manual [CPL1288Man.pdf](#)
- Architect's/Engineers Specs [CPL1288AE.doc](#)

CPL™ -1288 Dual-Channel Compressor/Limiter/Expander

Dual-Channel Compressor/Limiter/Expander

For over two decades, Crest Audio has been designing and building premium touring consoles and power amplifiers.

In response to customer requests, we've applied our experience to an integrated line of sound reinforcement products for smaller venues.

Same pristine sound quality. Same practical ergonomics. Same rugged construction.

Designed in the USA by engineers who know live sound inside and out.

Whether you're putting together your first system or just looking to upgrade a current mobile or

installed PA, you'll discover Crest Performance products that can make you sound better.

Get more information at www.crestperformance.com or better yet, ask for a demo at your Crest Performance dealer.

And then take advantage of our experience.

Block Diagram

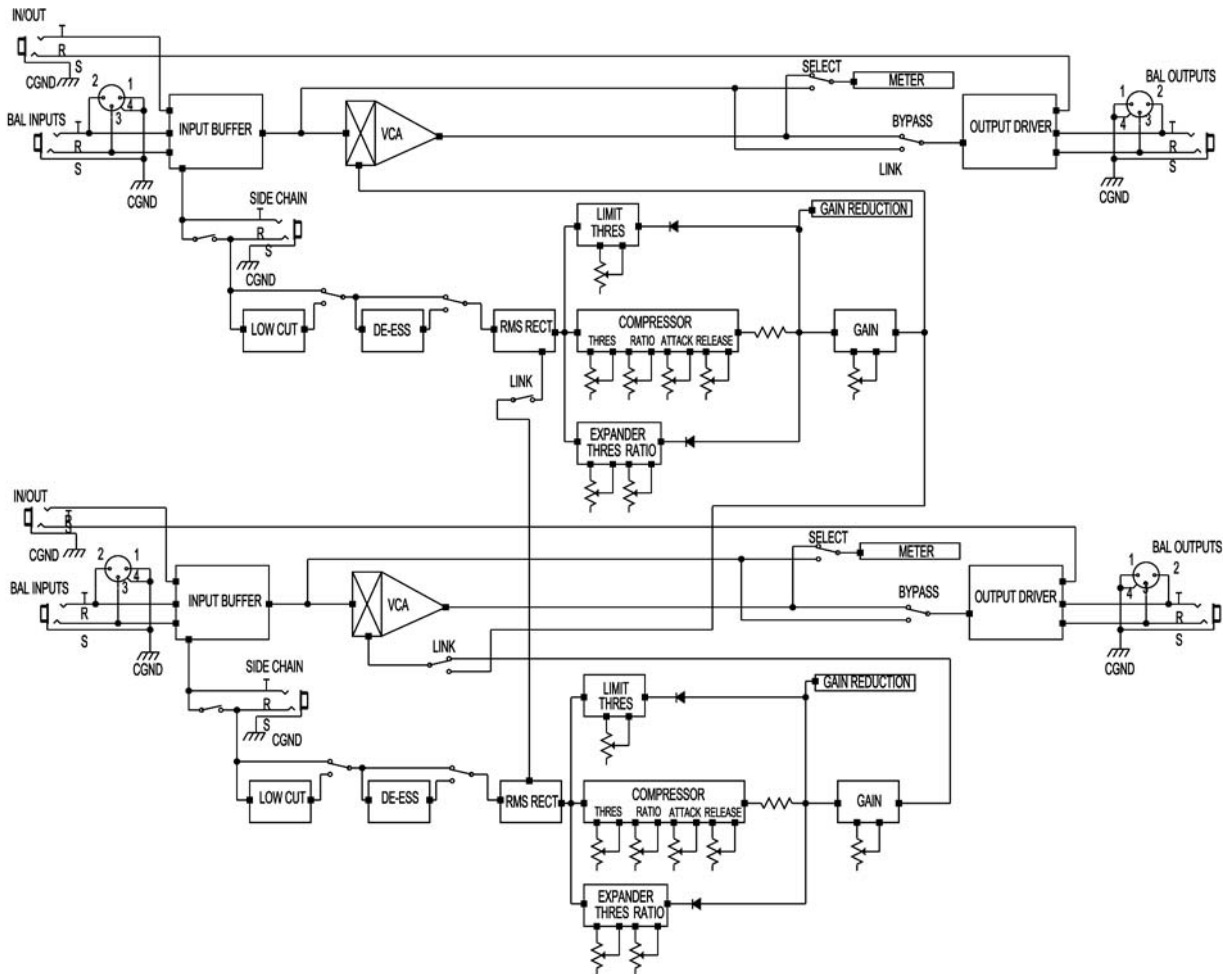

Other Crest Performance Products. Visit www.crest-performance.com or your Crest Performance dealer for details.

CPM-2462 24-input, rackmountable 4-bus mic/line mixer

CPM-9812P 10-input, 500+500W powered mixer

CJ/4 Professional DJ mixer

CP-6210/6220 Music mixer & DJ expander

CPX Series 600, 1000 & 1550W (bridged mono) power amplifiers

CPQ-1215 Dual 15-band equalizer

CPQ-1131 1/3-octave graphic equalizer

CPC-1223 2/3-way crossover

CPC-1234 2/3/4-way crossover

CPQ-1232 Digital anti-feedback system

CPS-1203 Spectrum enhancement system

LQ-P Series 10, 12 & 15-inch active 2-way mobile loudspeaker systems

LQ Series 10, 12 & 15-inch 2-way mobile loudspeakers

CPT Series 10, 12 and 15-inch 2-way speaker systems plus 2 sizes of fill speakers for permanent installation

LQ-15PSW 1000-watt, 15-inch active subwoofer

©2004 Crest Performance. All Rights Reserved. Specifications subject to change.

V1 1/14/03

2/2

CREST PERFORMANCE™

A Division of Crest Audio
16-00 Pollitt Drive, Fair Lawn, NJ, 07410 USA
866.812.7378 • sales@crestaudio.com
www.crest-performance.com