



Dual 15-band Graphic Equalizer CPQ™-1215

Dual 15-band Graphic Equalizer



CPQ-1215 Specifications

Filter Q 2.3

Filter Center Frequencies, Hz 25, 40, 63, 100, 160, 250, 400, 630, 1 k, 1.6 k, 2.5 k, 4 k, 6.3 k, 10 k, 16 k

Maximum Filter Boost/Cut ± 12 dB/± 6 dB

Output Noise

Bypass mode -99 dBu

Filter (Flat) Mode -95

Frequency Response ± 1 dB (20 Hz – 20 kHz)

Distortion 0.002% (20 Hz – 20 kHz)

Input Impedance Balanced 20 k Ohms

Output Impedance 200 Ohms

Maximum Input Level + 20 dBu

Maximum Output Level + 20 dBu (Unbalanced); + 26 dBu (Balanced)

Nominal Input / Output Levels 0 dBu

Input Headroom + 20 dB

Output Headroom + 20 dB (Unbalanced); + 26 (Balanced)

Maximum Gain Boost / Cut ± 12 dB

Low Cut Filter 40 Hz @ 24 dB/oct

Power Consumption Domestic: 120 VAC, 60 Hz, 12 Watts; International, 230 VAC, 50/60 Hz, 12 Watts

Dimensions (H x W x D) 1.73" x 19" x 7.375", 44mm x 483mm x 187mm

Weight 6.6 lbs., 3.0 kg

Graphic equalizers are workhorses in any live sound system. They can be used to compensate for room acoustic anomalies, beef up speaker system deficiencies, manually control feedback and a host of other situations where precise tonal control is required.

To say that Crest knows equalizers is an understatement. We've been designing EQ circuits for decades as part of our large mixing consoles. We know how to make them quiet...and how to keep them from introducing phase distortion into the sound.

Both the CPQ-1215 and CPQ-1132 are built with high-quality components and are engineered to withstand years of hard use in mobile or fixed installations.

CPQ™-1215

- Two 15-band mono, Constant-Q equalizers in one rack space
- 45mm sliders with selectable ±6dB or ±12dB boost/cut*
- Separate left/right-channel input controls with LED indicators for correct level-setting
- 40Hz Low Cut infrasonic filters
- Balanced XLR and unbalanced ¼" TRS inputs

*selectable via rear panel switch

Quality equalization for:

- Rock bands
- Churches
- Mobile DJs
- Clubs and restaurants
- Corporate A/V
- School auditoriums
- Hotel ballrooms
- Conference centers
- Rental systems
- Trade shows
- Museums and libraries



See also: Crest Performance CPQ-1131 31-band graphic equalizer

Spec sheet CPQ1131Spec.pdf

CPQ-1131 Manual CPQ1131Man.pdf

Architect's/Engineers Specs CPC1223AE.doc

DOWNLOADS @
www.crest-performance.com

This spec sheet CPQ1215Spec.pdf

CPQ-1215 Manual CPQ1215Man.pdf

Architect's/Engineers Specs CPQ1215AE.doc

V1 1/14/03

CPQ™-1215 Dual 15-band Graphic Equalizer

Dual 15-band Graphic Equalizer

For over two decades, Crest Audio has been designing and building premium touring consoles and power amplifiers.

In response to customer requests, we've applied our experience to an integrated line of sound reinforcement products for smaller venues.

Same pristine sound quality. Same practical ergonomics. Same rugged construction.

Designed in the USA by engineers who know live sound inside and out.

Whether you're putting together your first system or just looking to upgrade a current mobile or installed PA, you'll discover Crest Performance products that can make you sound better.

Get more information at www.crestperformance.com or better yet, ask for a demo at your Crest Performance dealer.

And then take advantage of our experience.

Other Crest Performance signal processors

CPS-1203 Spectrum Enhancement System



Spec sheet [CPS1203Spec.pdf](#)
 CPS-1203 Manual [CPS1203Man.pdf](#)
 Architect's/Engineers Specs [CPS1203AE.doc](#)

CPL-1288 Dual-Channel Compressor/Limiter/Expander



Spec sheet [CPL1288Spec.pdf](#)
 CPL-1288 Manual [CPL1288Man.pdf](#)
 Architect's/Engineers Specs [CPL1288AE.doc](#)

CPQ-1232 Digital Anti-Feedback System



Spec sheet [CPQ1232Spec.pdf](#)
 CPQ-1232 Manual [CPQ1232Man.pdf](#)
 Architect's/Engineers Specs [CPQ1232AE.doc](#)

CPQ-1215 Block Diagram

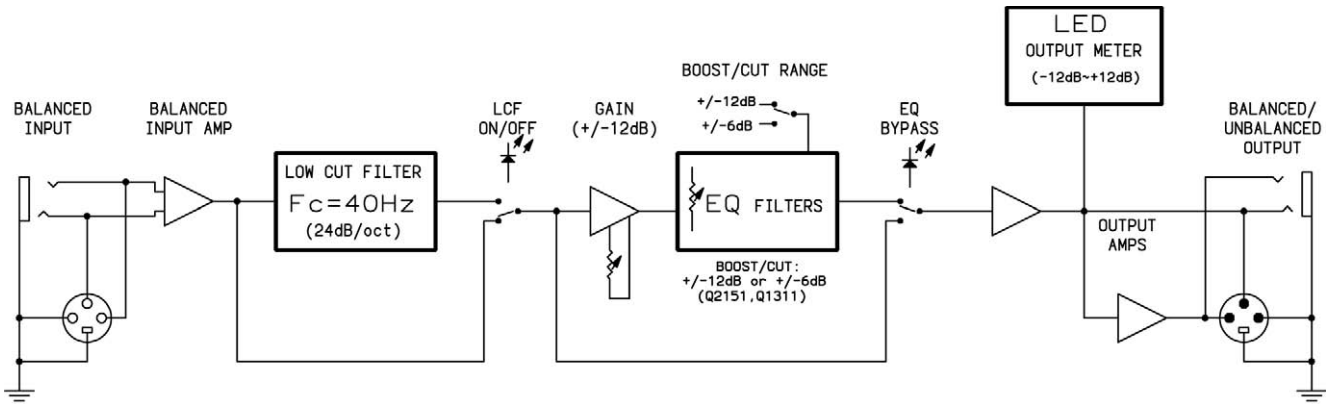

Other Crest Performance Products. Visit www.crest-performance.com or your Crest Performance dealer for details.

CPM-2462 24-input, rackmountable 4-bus mic/line mixer

CPM-9812P 10-input, 500+500W powered mixer

CJ/4 Professional DJ mixer

CP-6210/6220 Music mixer & DJ expander

CPX Series 600, 1000 & 1550W (bridged mono) power amps

CPQ-1131 1/3-octave graphic equalizer

CPL-1288 Dual-channel compressor/limiter/expander

CPC-1223 2/3-way crossover

CPC-1234 2/3/4-way crossover

CPQ-1232 Digital anti-feedback system

CPS-1203 Spectrum enhancement system

LQ-P Series 10, 12 & 15-inch active 2-way

mobile loudspeaker systems

LQ Series 10, 12 & 15-inch 2-way mobile loudspeakers

CPT Series 10, 12 and 15-inch 2-way speaker systems plus 2 sizes of fill speakers for permanent installation

LQ-15PSW 1000-watt, 15-inch active subwoofer

©2004 Crest Performance. All Rights Reserved.

V1 1/14/03

2/2

CREST PERFORMANCE

A Division of Crest Audio
 16-00 Pollitt Drive, Fair Lawn, NJ, 07410 USA
 866.812.7378 • sales@crestaudio.com
www.crest-performance.com