



CPQ-1232 Specifications

- Input Impedance** 40 k ohm
- Output Impedance** 120 ohm
- Dynamic Range** 103 dB_r @ 1 kHz ref to +18 dBu output 22 Hz to 22 kHz unweighted
- Total Harmonic Distortion** 0.005 % @ 1 kHz typical
- Input Sensitivity** +4 dBu nominal, +18 dBu full scale, -10 dBV nominal, +4 dBV full scale
- Sample Rate** 48 kHz
- Converters** 24-bit
- Frequency Response** ± 0.5 dB (20 Hz to 20 kHz, ref. 1 kHz)
- Input Level** Switchable +4 dBu and -10 dBV
- Output level** Switchable +4 dBu and -10 dBV
- Gain** Unity balanced, -6 dB unbalanced
- Connections**
Balanced combo female XLR/female ¼" TRS for input
Separate balanced male XLR and female ¼" TRS for output
RS-232 DB-9 for PC interface
- Other back panel controls** Front panel disable, Power-up recall select
- Power Requirements** Domestic: 120 VAC; 60 Hz; 25 Watts, International: 230 VAC; 50/60 Hz; 25 Watts
- Bypass** True power-off bypass
- Mounting** One EIA rack space
- Dimensions** (H x W x D) 1.75" x 19" x 8", 44.5mm x 482.6mm x 203 mm
- Weight** 7.1 lbs., 3.95 kg

Even if you're just getting started in live sound, you know what feedback is. While the CPQ-1232 is a very technical device, it's perfect for non-technical sound operators. Just as its name implies, it automatically identifies and suppresses microphone feedback so you can concentrate on running the mixer.

After your sound system is all set up, you boost each mic channel until feedback occurs. This "teaches" the CPQ-1232 where feedback problems can occur.

Then during the performance additional filters are constantly standing by to instantly kill any extra, unexpected feedback.

Why constantly fight feedback when Crest's digital technology can handle it for you 24/7?

CPQ™-1232

- Dynamically suppresses feedback using sophisticated "search & destroy" filters that find, lock in and kill offending frequencies
- Sixteen individual filters can operate simultaneously (eight dynamically react to input changes)
- Stereo or "dual mono" operation which enables 32 dynamically-controlled filters
- Set-and-Forget operation in fixed installations such as churches and auditoriums
- Four presets for your most common performance venues
- Rear panel Defeat button locks out inquiring fingers
- Extra Max "Panic" filters for quick control of sudden, severe feedback
- Balanced XLR and bal./unbal. ¼" TRS inputs and outputs
- Switchable +4dBu /-10dBV input levels
- RS-232 port for future upgrades (visit www.crestaudio.com for more information)



Precision digital feedback elimination for:

- Rock bands
- Churches
- Mobile DJs
- Clubs and restaurants
- Corporate A/V
- School auditoriums

- Hotel ballrooms
- Conference centers
- Rental systems
- Trade shows
- Theme parks
- Cruise ships
- Museums and libraries

DOWNLOADS @ www.crest-performance.com

- This spec sheet CPQ1232Spec.pdf
- CPQ-1232 Manual CPQ1232Man.pdf
- Architect's/Engineers Specs CPQ1232AE.doc

For over two decades, Crest Audio has been designing and building premium touring consoles and power amplifiers.

In response to customer requests, we've applied our experience to an integrated line of sound reinforcement products for smaller venues.

Same pristine sound quality. Same practical ergonomics. Same rugged construction.

Designed in the USA by engineers who know live sound inside and out.

Whether you're putting together your first system or just looking to upgrade a current mobile or installed PA, you'll discover Crest Performance products that can make you sound better.

Get more information at www.crestperformance.com or better yet, ask for a demo at your Crest Performance dealer.

And then take advantage of our experience.

Block Diagram

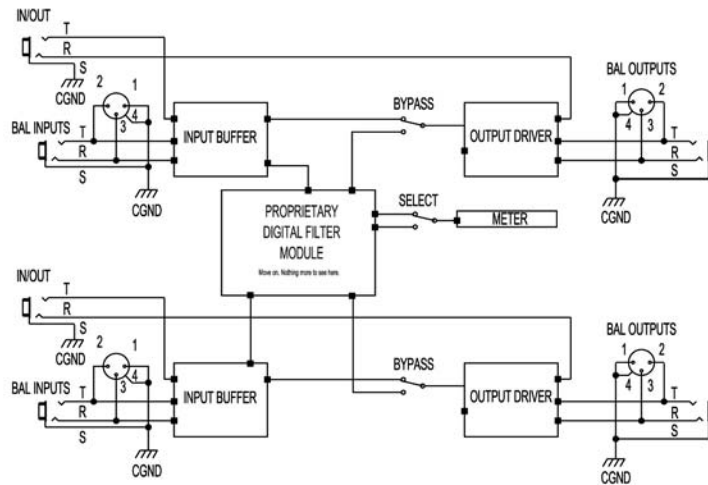

Other Crest Performance signal processors

CPS-1203 Spectrum Enhancement System



Specsheet [CPS1203Spec.pdf](#)
 CPS-1203 Manual [CPS1203Man.pdf](#)
 Architect's/Engineers Specs [CPS1203AE.doc](#)

CPL-1288 Dual-Channel Compressor/Limiter/Expander



Specsheet [CPL1288Spec.pdf](#)
 CPL-1288 Manual [CPL1288Man.pdf](#)
 Architect's/Engineers Specs [CPL1288AE.doc](#)

Other Crest Performance Products. Visit www.crest-performance.com or your Crest Performance dealer for details.

CPM-2462 24-input, rackmountable 4-bus mic/line mixer

CPM-9812P 10-input, 500+500W powered mixer

CJ/4 Professional DJ mixer

CP-6210/6220 Music mixer & DJ expander

CPX Series 600, 1000 & 1550W (bridged mono) power amps

CPQ-1215 Dual 15-band equalizer

CPQ-1131 1/3-octave graphic equalizer

CPC-1223 2/3-way crossover

CPC-1234 2/3/4-way crossover

CPL-1288 Dual-band compressor/limiter/expander

CPS-1203 Spectrum enhancement system

LQ-P Series 10, 12 & 15-inch active 2-way mobile loudspeaker systems

LQ Series 10, 12 & 15-inch 2-way mobile loudspeakers

CPT Series 10, 12 and 15-inch 2-way speaker systems plus 2 sizes of fill speakers for permanent installation

LQ-15PSW 1000-watt, 15-inch active subwoofer

©2004 Crest Performance. All Rights Reserved. Specifications subject to change.